

# Installation Instruction Radio Pulse Adapter Supercom 541

## General

The battery operated radio pulse adapter Supercom 541 is available with one or two pulse inputs. This robust device is ideally suited for the operation of measuring equipment for all types of energy supply and can be read off by means of the integrated, bidirectional radio link using mobile data acquisition. Seals may only be removed by authorised personnel. The national and local regulations as well as the manufacturer's specification must be observed!

## Installing the radio pulse adapter Supercom 541

- The radio pulse adapter Supercom 541 is designed for wall or DIN-rail mounting
- There must be a space of at least 30 cm between two radio transmitters
- Radiated heat and electrical interference fields close to the integrator must be avoided
- The radio pulse adapter must always be used according to its technical data. The permissible ambient temperature is 5...55°C

## Electrical connection (mains devices)

This radio pulse adapter left the factory in perfect technical and safety conditions. To maintain this status and to guarantee safe operation, the user must observe the instructions given in this document.

## Operating life

The radio pulse adapter is equipped with a long-life lithium battery, the operating life of which is reduced if more than 52 readings times are taken in a year.

## Real time and monthly values

The radio pulse adapter Supercom 541 has its own internal clock, which, at the end of each month, backs up the values from every registers. With the help of the radio modem Supercom 636, the values of the last 15 months can be read off. The date and time can be parameterised with the Tool 916 and the radio modem Supercom 636.

## Cable connections

To connect inputs (type IP54) loosen the bottom part of the cover. Connections must be made according to the diagram on the back of the cover.

## Metering inputs

The metering inputs are used to record pulses which emanate from metering contacts or outputs. The pulses from individual inputs are accumulated in a specific register, the value of which can be read off with the help of the radio modem Supercom 636. The inputs can be configured in such a way that they can count up to 20 pulses a second (20 Hz). The maximum accumulation capacity is 99'999'999 pulses.

The following types of "user information" for metering inputs can be stored in the memory of the radio module:

- Meter type (medium)
- Unit and value of pulses
- Identification of measuring point
- Output value of meter

## Radio read out

The radio pulse adapter Supercom 541 is identified by an 8-digits serial number, which is also used as radio communications address. The information can be read off from Monday to Sunday, between 6.00 and 20.00 hours.

## Initial operation

Put into service the radio pulse adapter with the help of the radio modem Supercom 636

- Install and connect the radio module
- Check the configuration
- Check the radio link
- Store all the parameters defined in the software Tool 916 into the radio module.
- Generate or simulate pulses at the metering inputs and take a reading to check the accumulation in the registers.

Make a reading from the device that's connected at the communications port.

## Security seals

Seals can vary from country to country, therefore local regulations must be observed.

User seals must be fitted to the thermal energy meter, screw fittings and temperature sensors to prevent unauthorised modification or manipulation. Seals may only be removed by authorised personnel. Otherwise the guarantee is no longer valid.

## Servicing and repair work

Servicing and repair work may only be carried out at Sontex' premises or at authorized service points according to Sontex' service schedule.

## Technical Data

### General

Operating temperature	5° to 55°C
Storage temperature	-20 to 70°C
Length of the cable for pulses input	
- Variant without cable (IP54)	max. 3.00 m according the homologation
- Variant with cable (IP68)	max. 1.50 m
EMC-Approval	according to IEC / EN 61000

### Radio communication

Method	FSK, bidirectional
Frequency	433.82 MHz
Protocol	Radian, EN60870 (M-Bus)
Baud rate	2'400 Baud
Transmitting power	< 10 mW
Range	approx. 30 m*

\* This value depends on the structure of the building.

Due to the physical conditions, the sending and receipt ranges can vary in buildings or be completely impossible.

### Data Memory

EEPROM	24 hours storing
--------	------------------

### Electrical data

Power supply	3V Lithium-long life battery
Life time	12 + 1 years, based on 52 read outs / year

**Pin connector or wire**

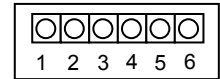
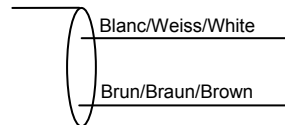
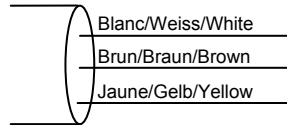

**Wiring diagram Model 0541Rx000 (IP54)**

1. Ground
2. Pulses input C1
3. Fraud input C1
4. Pulses input C2
5. Fraud input C2 or reverse flow C1
6. Ground

**Wiring diagram Model 0541Rx101 (IP68)**

- Cable C1:
- White: Ground
  - Brown: Pulses input C1
  - Green: reverse flow C1
  - Yellow: Fraud input C1

**Wiring diagram Model 0541Rx202 (IP68)**

- Cable C1:
- White: Ground
  - Brown: Pulses input C1
  - Green: reverse flow C1
  - Yellow: Pulses input C1
- Cable C2:
- White: Ground
  - Brown: Pulses input C2

**Wiring diagram Model 0541Rx303 (IP68)**

- Cable C1:
- White: Ground
  - Brown: Pulses input C1
  - Yellow: Fraud input C1
- Cable C2:
- White: Ground
  - Brown: Pulses input C2
  - Yellow: Fraud input C2

**Dimension**

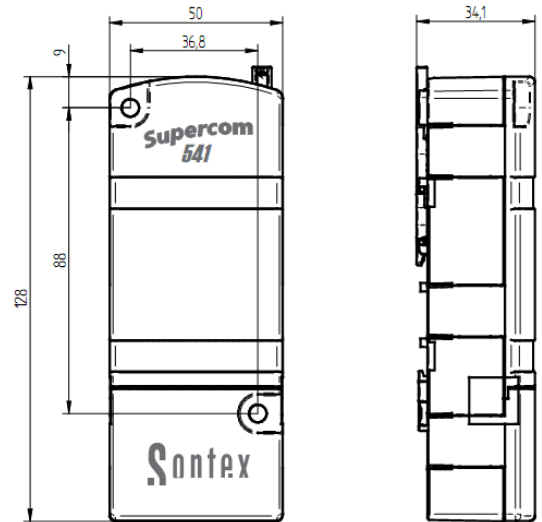

The IP68 versions of the radio pulse adapter Supercom 541 are hard-wired ex factory. Pay attention that during the final configuration with the PDA Software Sontex916 the preconfigured functions are not modified.

**Electrical and dynamic specification**

**Pulses input**

	min	Max
Frequency	0 Hz	20 Hz
t1 (open)	12.5 ms	---
t2 (close)	2 ms	---

	Open contact	Closed contact
Vin max	2.3 V	0.5 V
Vin min	1.2 V	0 V
Iin max	0.5 uA	1.0 uA
Iin min	0 uA	0.9 uA
R min	2.7 MΩ	0 Ω
R max	---	500 KΩ

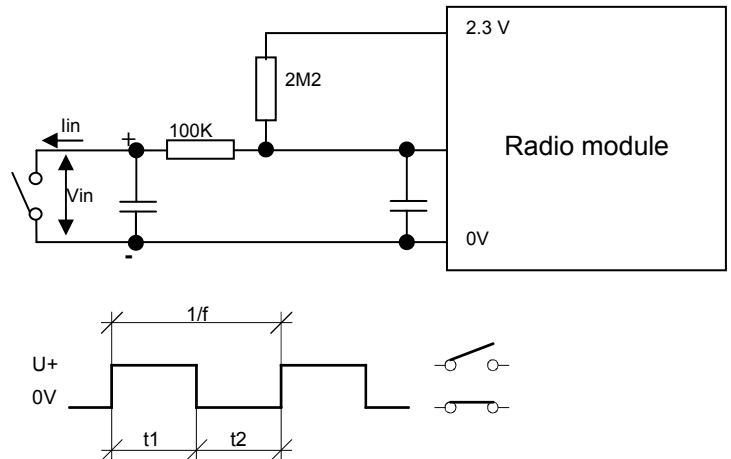

- Note:**
- If pulse generators with an open collector are connected, plug in the collector to the inputs terminals 2 or 4 and the reference potential (0 V) to the terminals 1 or 6.
  - The reference potentials (0 V) of the pins 1 and 6 are electrically linked in the radio transmitter.

**Technical Support**

For technical support, please contact your local Sontex agent or Sontex SA directly.  
Hotline Sontex: [sontex@sontex.ch](mailto:sontex@sontex.ch), +41 32 488 30 04

Declaration of conformity acc. to R&TTE 1999/5/CE

The detailed declaration of conformity can be found on our homepage: [www.sontex.ch](http://www.sontex.ch)  
Technical modifications subject to change without notice