

Compact Static Heat Meter of High-Tech Composite



Application

The **Superstatic 789** is a lightweight and robust compact heat meter consisting of a high-tech composite flow meter, a detachable integrator with a wide range of communications options and a pair of temperature sensors. It's used in home automation, local and district heating/cooling systems to measure the consumption of heating or/and cooling energy for individual billing.

The **Superstatic 789** is designed on the basis of the proven **fluid oscillation** principle used exclusively by Sontex. Thanks to the use of a static flow sensor, the heat meter **Superstatic 789** does not have any moving parts and thus no wear. The fluid oscillation principle guarantees a high stability and repeatability for a reliable and precise measurement of flow and thermal energy. It is optimally suited for glycol and other mixtures.

It's built for flows of q_p 1.5 m³/h and q_p 2.5 m³/h and measures the temperature within the range of 0°C to 110°C. Through its two additional optional pulse inputs, it is possible to connect, e.g., two water meters (hot and cold) and read their values remotely via the heat meter.

The **Superstatic 789** meets the requirements of the European Measuring Instruments Directive (MID) 2014/32/EU and the standard EN 1434 class 2.

Benefits

Permanent flow detection thanks to the fluidic oscillation measuring principle

- **Flow meter of High-Tech Composite lightweight and robust**
- Corrosion resistant materials
- No moving parts, thus no wear
- Not sensitive to dirt, air bubbles and liquids with changing viscosity
- Self-cleaning thanks to the fluidic oscillation pulse in the flow meter
- Long-term stability, accurate and reliable measurement

Standard features

The heat and cooling meters **Superstatic 789** are optimized for the measurement and calculation of energy consumption in district or local heating systems.

- Configured as a heat meter MID with temperature sensors Ø 5 mm, 1.5m
- Optical interface for readout and 6+1 years battery
- Easy to operate and read
- Non-volatile EEPROM memory, that keeps stored data even in case of power failure
- 18 monthly energy values for heat energy and volume
- Self-monitoring and error display

Sizes

The **Superstatic 789** is available in the following sizes:

- Flow meter for qp 1.5 m³/h, with a length of either 110 mm or 130 mm,
- and qp 2.5 m³/h 130 mm

Options

The **Superstatic 789** can be ordered with following options

- Ø 5,2 mm or Ø 6 mm temperature sensors
- 12+1 years battery
- One of the following communications options:
 - Self-powered M-Bus
 - Bidirectional Radio SONTEx interface.
 - Wireless M-Bus.
 - Two pulse outputs either heating or cooling energy consumption and volume, or heating and cooling energy consumption
- Two additional pulse inputs

Functions

- Measure and record energy consumption and volume of the flow in heat or cooling applications
- Optionally measure and record a second “energy consumption”, for heat/cooling applications
- If two additional inputs were configured then record the provided values. The configuration can be done either through the optical interface, or via M-Bus or by radio SONTEx
- Display of consumption data depending on configuration:
 - 18 monthly energy and volume values
 - 18 monthly cooling energy values
 - 18 monthly values of additional pulse input 1
 - 18 monthly values of additional pulse input 2
 - Set day values
- Display operating data including self-monitoring with error display

Fluid oscillation flow sensor: The principle

Picture1: The liquid passes through a special insert, the oscillator. Before passing the oscillator, the liquid is led to a nozzle and accelerated to a jet (oscillating jet). Opposite of the nozzle, the jet is redirected to the left or right into the channel. Due to the differential pressure generated in the channel, part of the liquid flows to the piezo-sensor above and part flows back to the pipe. The pressure of the liquid on the piezo-sensor generates an electrical pulse. Thus the liquid flows back to the pipe through a return loop and redirects the jet into the other channel. The liquid of this channel flows on the other side of the piezo-sensor and generates again an electrical pulse.

Picture 2: The animated top view shows the oscillating jet and its differences in velocity: The oscillation jet accelerated by the nozzle has the highest velocity and is visible in red. The jet that has slowed down is represented in blue.

The electrical pulses generated by the piezo-sensor with differential pressure correspond to the movement, the frequency of the jet. The electrical pulses are processed, amplified and filtered by the electronics. The electrical pulses are recorded by the integrator connected through a cable to the flow sensor and converted into flow. The frequency of the oscillation jet, i.e. the electrical pulse, is proportional to the flow.

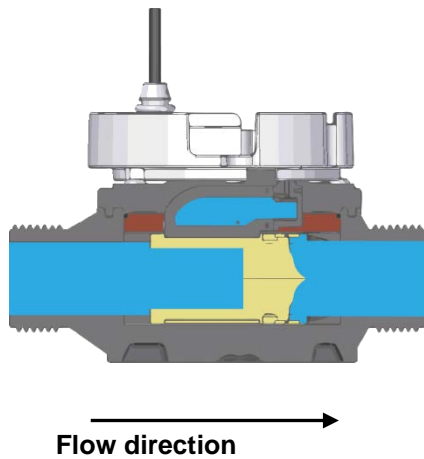

Picture 1: Section through the flow sensor

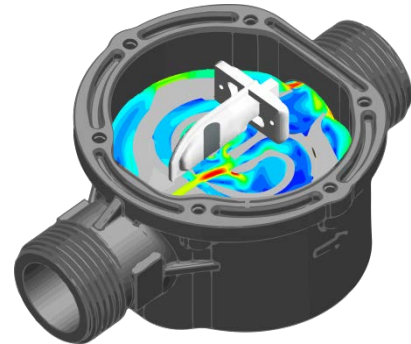

Picture 2: Schematic of oscillator with oscillating jet (RED)

Temperature sensors

The pair of temperature sensors Pt 1'000 is connected to the integrator and is an integral part of the heat meter. The sensor with a colourless marking is mounted and sealed directly into the flow sensor. The temperature sensor with the orange marking must be mounted in the pipe "opposite" to the **Superstatic 789**. The temperature sensors mustn't be changed or modified.

Integrator

The integrator is equipped with a large 8-digits display and can be rotated by 360°. The integrator can be separated from the flow sensor and be installed separately. A cable of 0,6 meter connects the integrator to the flow sensor. The housing has a protection index of IP65 against dust and humidity.

Display

The LCD display of the **Superstatic 789** has a large, clear design and high contrast, making it easy to read the data.

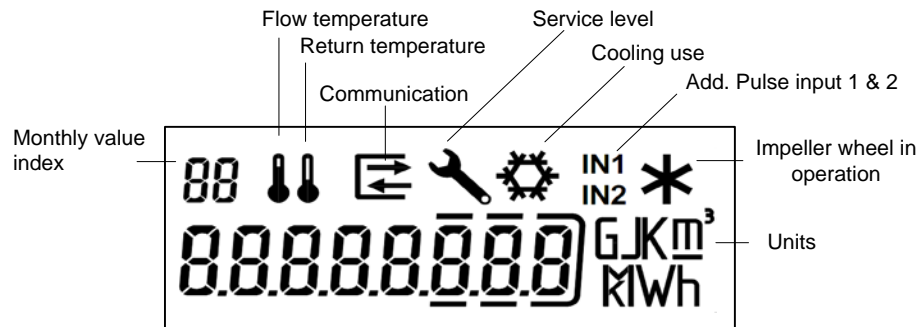

Display sequences

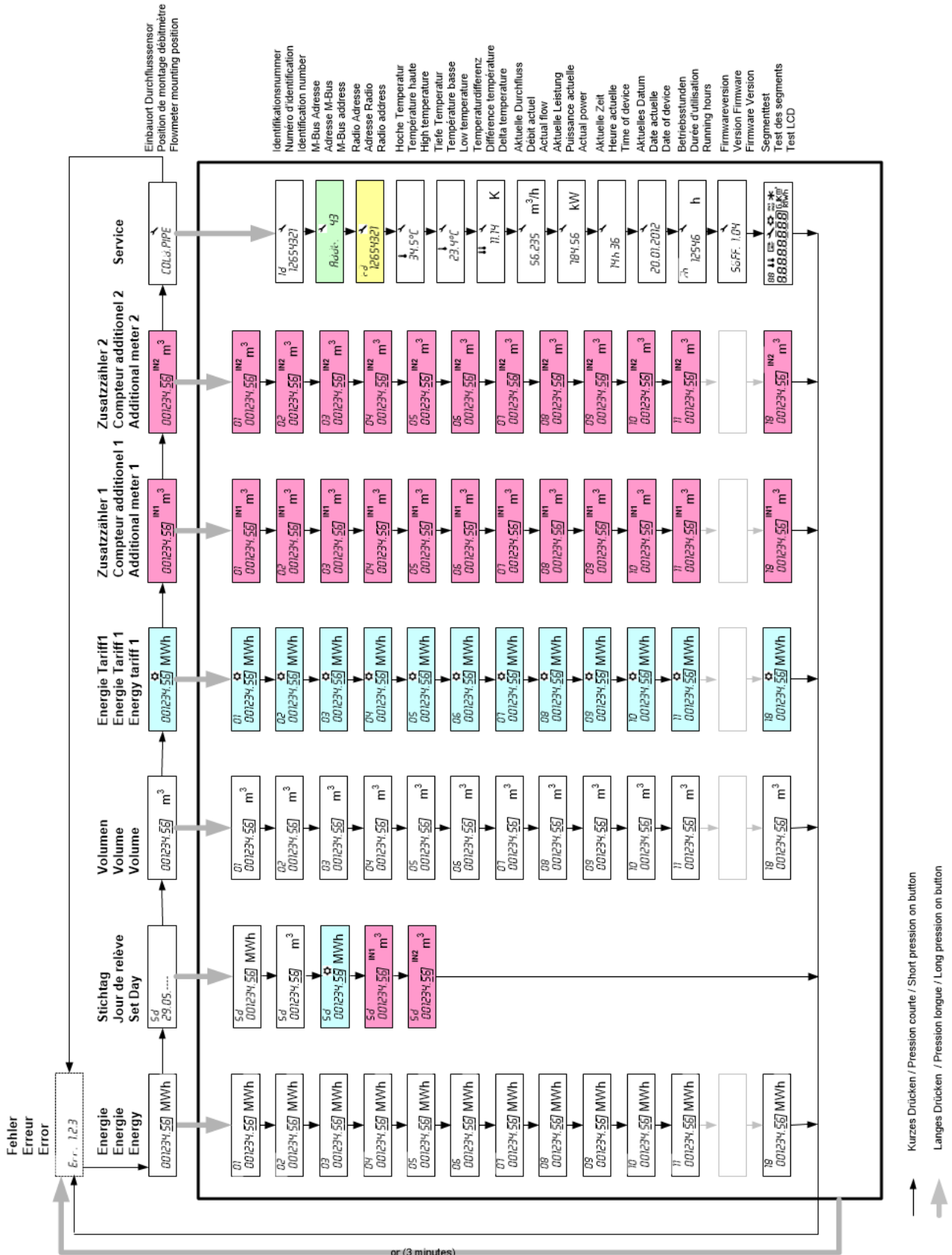

Error messages

Err 1	Flow higher than 1.2 x q _s or faulty flow sensor.
Err 2	Measured temperature out of range or faulty temperature sensor.

Energy calculation

The flow sensor counts up the volume of the liquid flowing through the sensor. The thermal energy consumption, respectively the heating and cooling energy are calculated by means of the temperature difference between hot and cold pipe, the recorded volume, and the heat coefficient. The latter takes into consideration the density, the viscosity and the specific heat of the liquid used. All these are dynamically adapted in function of the temperature.

Solar-, cooling and other installations

The standards allow for approvals using water as heating and or cooling liquid and the **Superstatic 789**, while having received all according approvals, ensures also a precise measurement with other liquids.

The calculator contains the data for many different special liquids and, by means of the free software Prog7x9, it is possible to select the liquid, its level of concentration if so defined and be set to calculate properly the energy consumption.

Cooling energy

The cooling energy in combined heat/cooling applications is stored in another memory than the heat energy and will be cumulated only if the two following conditions are fulfilled:

- Temperature difference(Δt) > -0.5K
- Supply temperature < 18°C

The cooling energy has the same physical unit as the heat energy. The cooling power and the temperature difference are in this case displayed with a minus sign (-). If required it is possible to order the **Superstatic 789** with another threshold than the 18°C.

Non-volatile memory

The device parameters, as well as the cumulative values for energy and volume, cooling energy, monthly values, set day values, values of the pulse input counters 1 and 2, operating hours and error type are stored in a non-volatile memory (EEPROM), where they are saved even in case of a power failure (e.g. changing batteries). Once an hour and in the event of battery failure, the cumulative values are updated in the EEPROM.

Monthly values

At the end of each month, the monthly values are stored.

Depending on the configuration a total of 18 monthly values of heat energy, volume, cooling energy and of the additional pulses inputs 1 and 2 are memorized in the integrator.

Pulse inputs

As an option the **Superstatic 789** offers the possibility to integrate two additional pulse inputs such as from a hot water and a cold water meter.

Communication options

Several communication interfaces are available.

The configuration of the selected communication option of the **Superstatic 789** can be carried out with the free software Prog7X9 from Sontex.

Configuration

The heat meter is delivered ex works in the “storage” mode, it means it does not count and the display shows "Disabled". The storage mode is active as long as the meter is not sealed "Seal".

Optionally, the “Config” menu can be ordered in addition. The transition from “storage” mode to "Config" menu is made with a short press on the orange navigation button. Another short press gives access to the whole sequence of the "Normal" mode.

In the "Config" menu, a long press on the button will change the below settings:

- Flow meter mounting position in the installation. Hot (HOT PIPE) or cold side (COLD PIPE).
- Energy unit (0.1kWh, 1 kWh, 0.001MWh, 0.01MWh, 0.001GJ and 0.01GJ).
- Volume unit (0.01 m3 and 0.001m3).

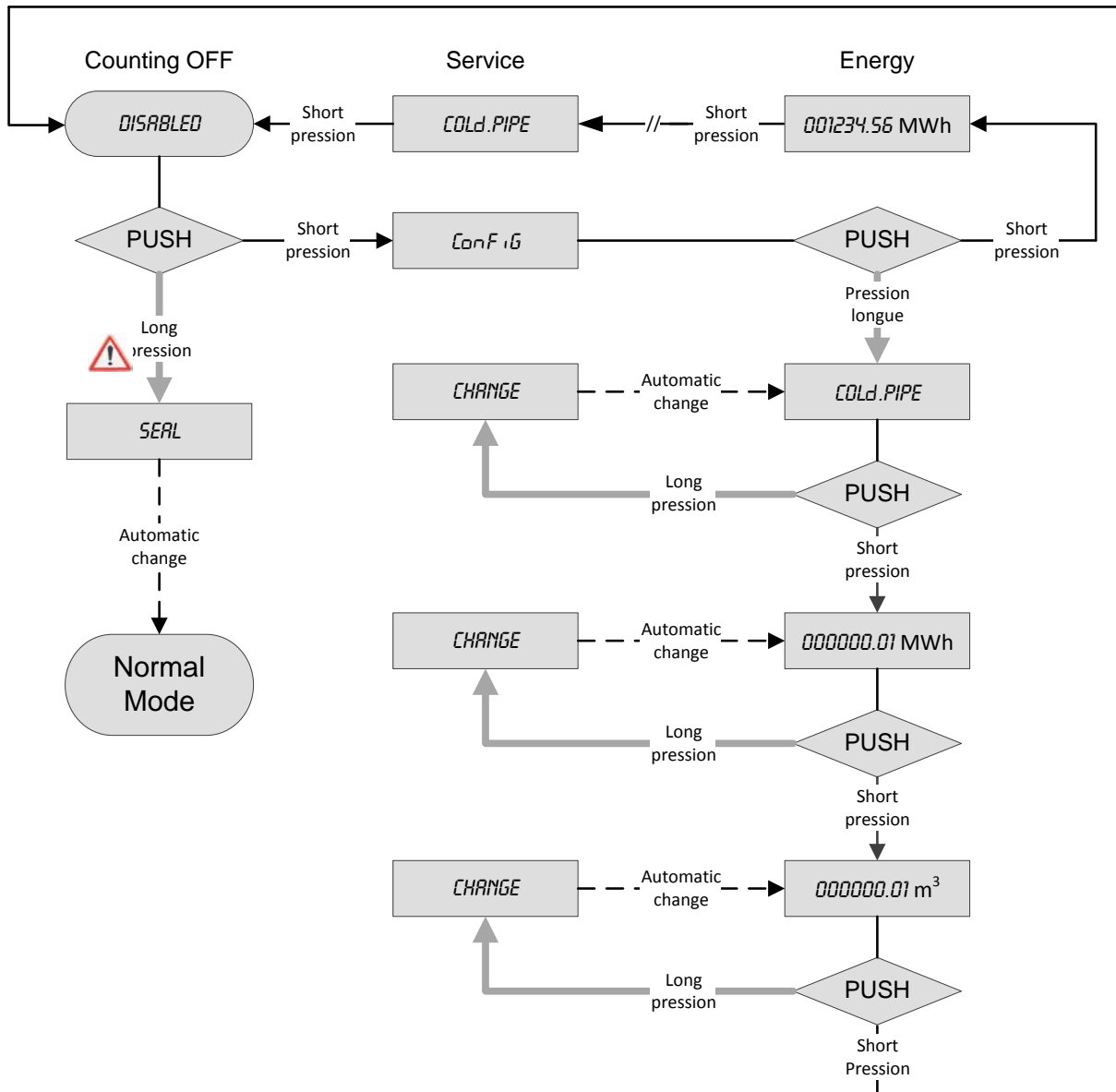

TECHNICAL DATA

Temperature sensors

2 wire temperature sensor	Pt1'000
Diameter	Ø5.0; Ø5.2, Ø6.0 mm
Cables length	1.5 m

Measurement

Approved temperature range	0...110°C
Differential range	3...75 K
Response limit	0.5 K
Temperature resolution t (display)	0.1 °C
Temperature resolution Δt (display)	0.01 K
Temperature-measurement cycle at nominal flow	10 seconds
Flow-measurement cycle	Permanent

Integrator General

Environment class	C
Mechanics	M1
Electronics	E1
Battery protection class	III
Cable connection between flow sensor and integrator	0.6 m, fix
Integrator Protection index	IP 65
Operating temperature	5...55°C
Operating temperature with radio option	5...40°C
Storage and transport temperature	-10...60°C

Display & Display units

	8-digits LCD
Energy	kWh, MWh, GJ
Volume	m ³
Additional pulse inputs	Volume or pulses
Temperature	°C
Δ Temperature	K

Power supply

Lithium Metal Battery (≤ 1g) 3VDC	6+1 or 12+1 years
-----------------------------------	-------------------

Powered by M-Bus line

1 device = 2 M-Bus charges (max 2 x 1.5mA)

Pulse output

Open drain (MOS Transistor) V _{CCmax} : 35 V _{DC} ; I _{CCmax} : 25mA	1 Hz, 500 ms
--	--------------

Pulse inputs with a dry contact

Power supply _{internal}	2.3 V _{DC}
R _{pull UP internal}	2 MΩ
Pulse factor	0...999.999 m ³ /Imp or without unit

Fluidic Oscillation Flow Sensor

qp	Threaded connection		Mounting length mm	Mat.	PN bar	Maximal flow	Minimal flow	Low flow threshold value (50°C) l/h	Threaded hole for sensor	Total Meter Weight kg	Kvs value (20°C) m ³ /h	Pressure loss at qp
	m ³ /h	G"				DN	m ³ /h					l/h
1.5	3/4"	(15)	110	Comp	16	3	15	10	Yes	0.72	3.4	0.2
1.5	1"	(20)	130	Comp	16	3	15	10	Yes	0.74	3.4	0.2
2.5	1"	(20)	130	Comp	16	5	25	17	Yes	0.75	5.5	0.2

Comp = High-Tech Composite
16 bar = 1.6 MPa

Pressure loss curve

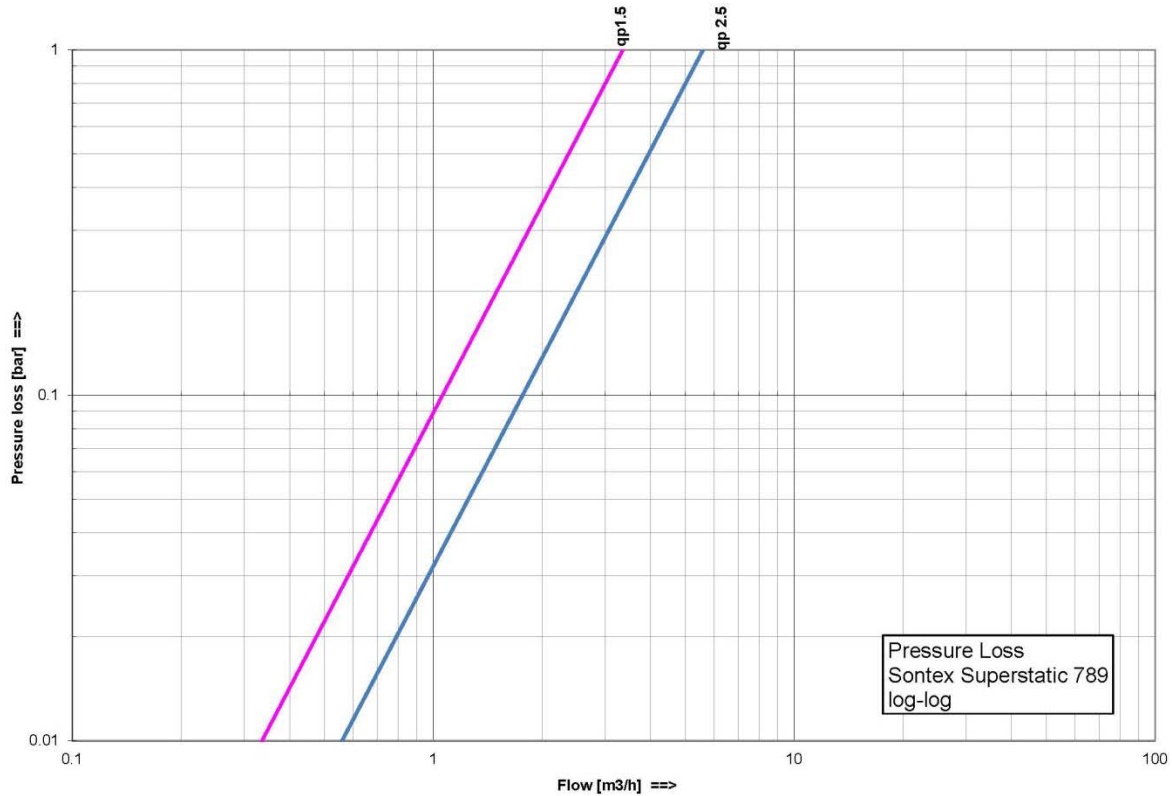

Metrological class

EN 1434 class 2

Mounting

The Superstatic 789 should not be mounted on the side where the continuous operating temperature of the liquid exceeds 90°C or is below 5°C.

Length of straight section fitted upstream/downstream of each flow meter (EN1434):

U3 / D0 for: L=110mm
U0 / D0 for: L=130mm

Flow sensor protection index

IP68

Dimensions

	qp 1.5 m ³ /h	qp 1.5 m ³ /h	qp 2.5 m ³ /h
Mounting length [L]	110 mm	130 mm	130 mm
Integrator	110.2 x 86.8 mm	110.2 x 86.8 mm	110.2 x 86.8 mm
Total height	118.5 mm	118.5 mm	113.4 mm
Height from the axis of the tube	90.0 mm	90.0 mm	87.3 mm
Height without integrator	54.5 mm	54.5 mm	52 mm

Superstatic 789, qp 1.5 m³/h
(L: 110 mm / 130 mm)

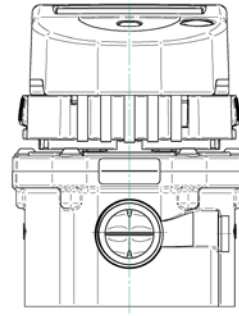
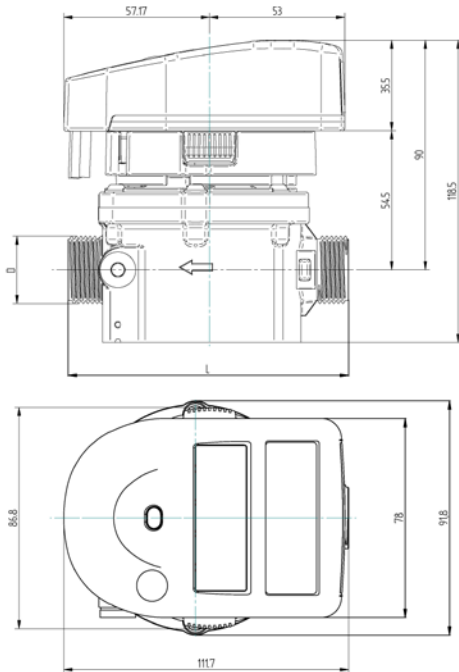

Superstatic 789, qp 2.5 m³/h
(L: 130 mm)

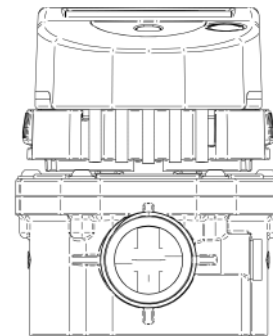
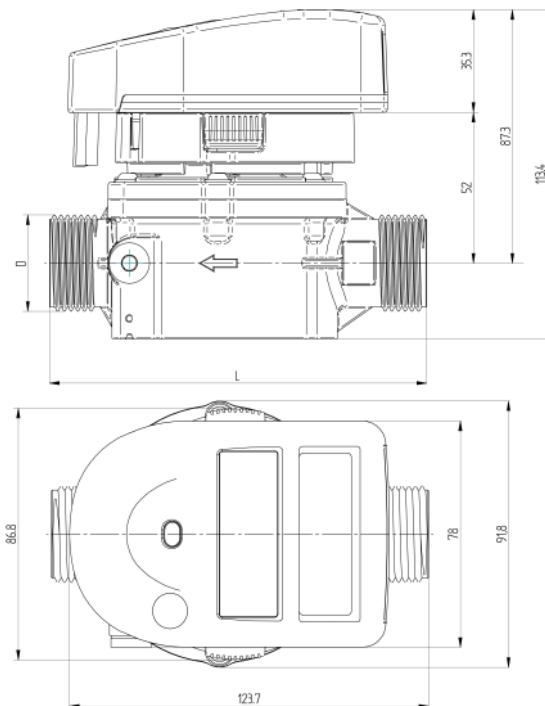

Technical support

For technical support, please contact your local Sontex agent of Sontex SA directly.

Hotline Sontex:

sontex@sontex.ch

+41 32 488 30 04

CE conformity according to

Directive MID 2014/32/EU

RED 2014/53/EU

Detailed declarations of conformity can be found on our homepage: www.sontex.ch

Modifications subject to change without notice

Data Sheet Superstatic 789 EN 29-05-2017

© Sontex SA 2016